

## 2/2 high pressure valve NW 15 to 32 for water and oil, max. 320 bar for plate mounting



### TECHNICAL DATA

The 2/2 directional control plate mounting valves listed in the table release or block a flow current. They are robust electromagnetically hydraulically operated seat valves. The connection bores between valve and connection plate are sealed by means of chambered O-rings. The working piston of the main valve is supported at two points and extended to the outside through the valve housing. This provides the possibility to attach an optical, mechanical, or electrical position indicator. The valve is sealed by pressing two metal surfaces against one another. In contrast to slide valves, there are no leakage losses in the closure of the valve. By fitting orifice plates or an intermediate plate with switch period adjustment between the pilot and main valves, the control medium can be throttled. This influences the switch period of the main valve. Throttle gap or throttle grooves on the main valve piston prevent undesirable pressure surges during the switching process.

This type of seat valves as individual valves or combined with other control elements into compact control systems are used wherever reliable sealing is required under difficult conditions, e.g. press and rolling mill engineering. There are no particular requirements as regards the lubrication capability of the medium. Via the associated pilot-control valve, the valves can be operated manually, mechanically, pneumatically, hydraulically or electrically using direct or alternating current. They are also available in protection class (Sch) and (Ex) d2/G5. For all standard supply voltages, control electromagnets are available.

### Special features

The valves are insensitive against vibrations and pressure surges in the hydraulic system. The emergency manual controls fitted as standard can be locked in position and are accessible only by removing the type plates; they are thus protected against accidental activation. The respective position of the valve pistons can be detected optically. Valve response times are fast. All wear parts are made of corrosion resistant materials, easy to access, and fast to replace.

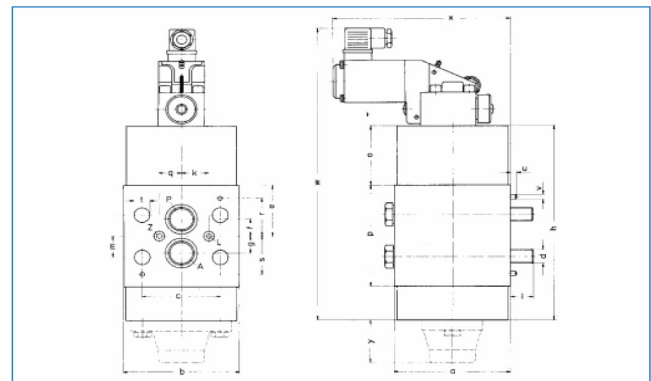

O-ring seal for ports

NW	P	A	L	Z
15	18*2,5	18*2,5	8*2	8*2
25	30*3	30*3	8*2	8*2
32	38*4	38*4	8*2	8*2
40	47*4	47*4	8*2	8*2

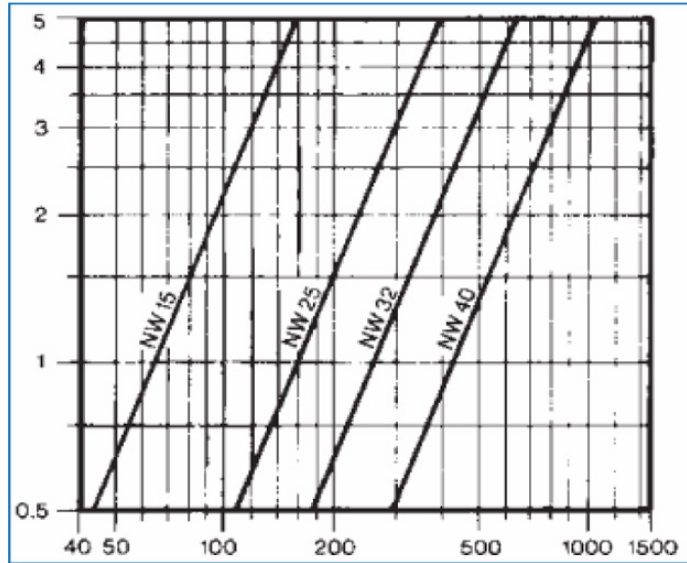
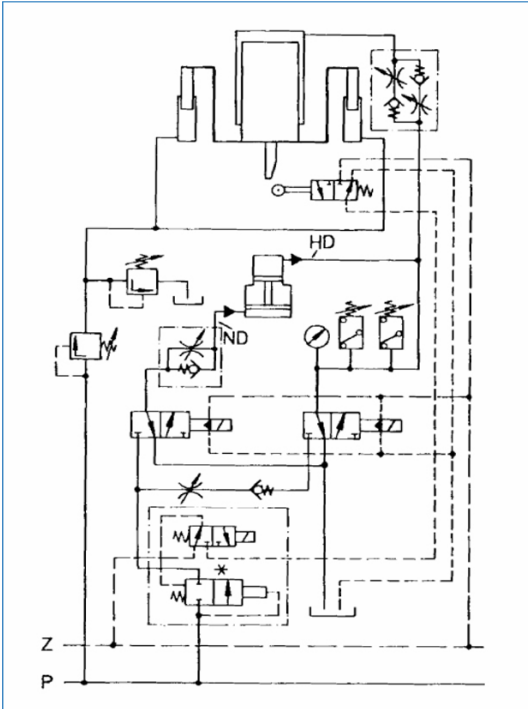

Ext. controlled with closing spring

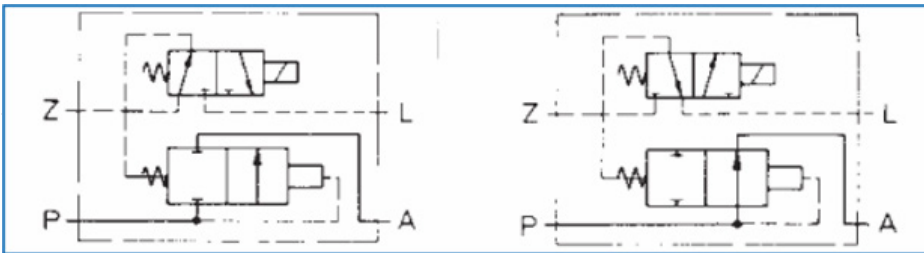

- 2/2BAV-015-06-XLS-NNEN-25
- 2/2BAV-025-06-XLS-NNEN-25
- 2/2BAV-032-06-XLS-NNEN-25
- 2/2BAV-040-06-XLS-NNEN-25

Ext. controlled with opening spring

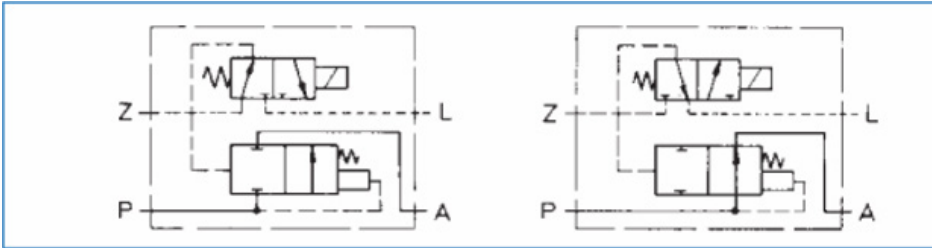

Type  
 2/2BAV-015-06-XLO-NNEN-25  
 2/2BAV-025-06-XLO-NNEN-25  
 2/2BAV-032-06-XLO-NNEN-25  
 2/2BAV-040-06-XLO-NNEN-25

Self-controlled with closing spring

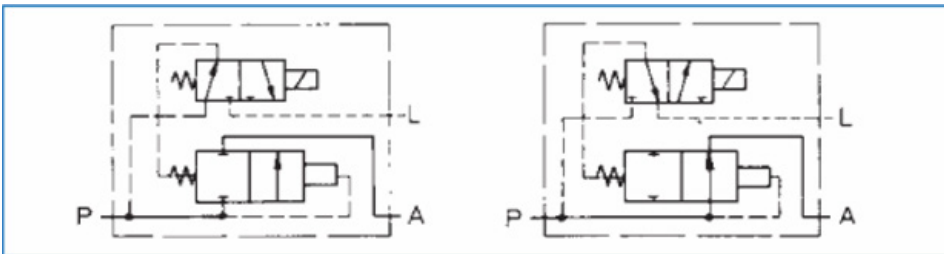

Type  
 2/2BAV-015-06-IIS-NNEN-25  
 2/2BAV-025-06-IIS-NNEN-25  
 2/2BAV-032-06-IIS-NNEN-25  
 2/2BAV-040-06-IIS-NNEN-25

Self-controlled with opening spring

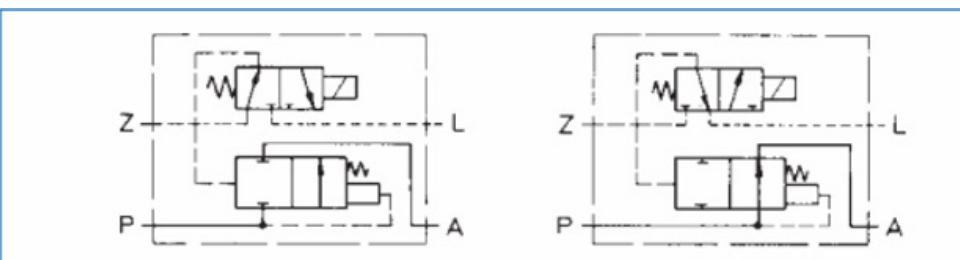

Port „Z“ is no longer required  
 Type  
 2/2BAV-015-06-IIO-NNEN-25  
 2/2BAV-025-06-IIO-NNEN-25  
 2/2BAV-032-06-IIO-NNEN-25  
 2/2BAV-040-06-IIO-NNEN-25