

2/2 directional control seat valve, 3/2 directional control seat valve

Nw3 and NW6, for Water, Oil and Air

- Protection against accidental operation
- Operating magnet protected against dirt and humidity
- Operating elements can each be rotated through 90°
- Wear parts are easily accessible and can be replaced quickly

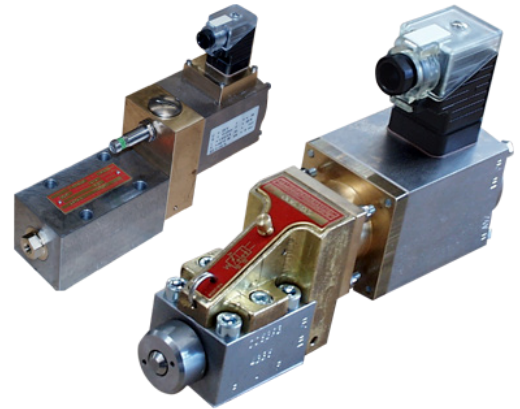

TECHNICAL DATA

The valves are used for water or oil hydraulic control systems. They can also be used as pilot-control valves.

Type

Directional control ball seat valve

Connections

Plate mounting with O-ring seal on request available with connection plate

Connection thread

NW3 = R1/4" or 1/4" NPT

NW6 = R3/8" or 3/8" NPT

Medium

Water, oil or air must be specially mentioned when ordering

Viscosity

1 to 300 cSt

Ambient temperature

Depends on control element, see table „Technical data of control elements“, higher temperatures on request

Seals

NBR, other seal materials available upon request

Sealing

Ball on seat

Pressure range

0 to 320 bar (630 bar)

for 3/2 dir.:

The pressure in connection „R“ must not exceed 50% of working pressure

Switching time

Depends on operating pressure and operating temperature (see table: technical data of control elements)

Fitted position

Any

Flow direction

2/2W: From „P“ to „A“

3/2W: From „P“ to „A“ or from „A“ to „R“

the connections „P“, „A“, and „R“ must not be mixed up

Flow rate for liquids

Max. 20l/min at NW6

Max. 5l/min at NW3

Operating modes

Electric, hydraulic, pneumatic, mechanical or manual operation

Materials

All parts coming into contact with the flow medium are made of corrosion resistant materials

Special features

The valve is characterized by fast response times. The solenoid plunger of the electromagnet is dual-supported and thus protected against wear. By means of a diaphragm seal between the pushrod and the solenoid plunger chamber the control electromagnet is protected against dirt and humidity. The arrestable manual operation device can be accessed by removing the type plate and is thus also protected against any accidental operation. The electric magnet and all other control elements can each be rotated through 90°. All wear parts are easily accessible and quick to replace.

VALVE VERSION “POSITIVE“

(Valve is closed when magnet is de-energized)

Fig. 1 (electromagnet de-energized):

The pressure spring (2) presses the valve ball (4) via pushrod (3) into the valve seat (5). The pressure of the medium in infeed “P” supports the pressure spring action (2). Thus the passage from infeed “P” to working line “A” is blocked.

Fig. 2 (electromagnet energized):

When the electromagnet (1) is switched on, the solenoid plunger (6) presses the valve ball (4) - via lever (7) and pushrod (8), and against the force of the pressure spring (2) and the pressure of the medium in the infeed “P” - from its valve seat (5). Now the passage from infeed „P“ to working line „A“ is clear.

Elektromagnet spannungslos Elektromagnet unter Spannung

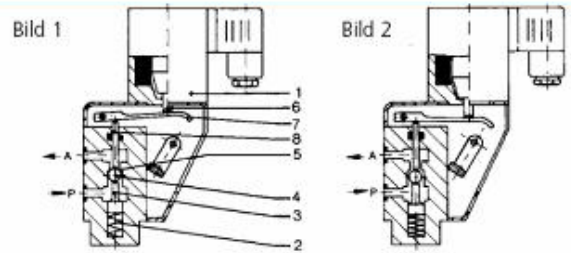

A	Arbeitsleitung	4	Ventilkugel
B	Zulauf	5	Ventilsitz
1	Elektromagnet	6	Tauchanker
2	Druckfeder	7	Hebel
3	Stößel	8	Stößel

VALVE VERSION “NEGATIVE“

(Valve is open when magnet is de-energized)

Fig. 1 (electromagnet de-energized):

The pressure spring (2) lifts the valve ball (4) via pushrod (3) from the valve seat (5). Thus the passage from infeed „P“ to working line „A“ is clear.

Fig. 2 (electromagnet energized):

When the electromagnet (1) is switched on, the solenoid plunger (6) presses the valve ball (4) - via lever (7) and pushrod (8), and against the force of the pressure spring (2) and the pressure of the medium in the infeed „P“ - into the valve seat (5). Now the passage from infeed „P“ to working line “A” is blocked.

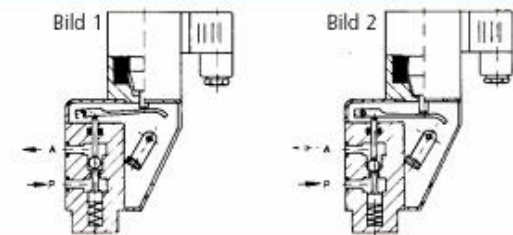

A	Arbeitsleitung	4	Ventilkugel
B	Zulauf	5	Ventilsitz
1	Elektromagnet	6	Tauchanker
2	Druckfeder	7	Hebel
3	Stößel	8	Stößel

TYPE AND ORDER EXAMPLE

Operating modes	Symbol	Type: NW3
Electromagnetic Example for 24 volts		2/2KSV-03P-25NBNN-ED024 [†] 2/2KSV-03N-25NBNN-ED024 ^{**}
Hydraulic		2/2KSV-03P-25NBGN-Z320 [†] 2/2KSV-03N-25NBGN-Z320 ^{**}
Pneumatic		2/2 KSV-03P-25NB GNN-Z064 [†] 2/2 KSV-03N-25NB GNN-Z064 ^{**}
Mechanical(roller)		2/2KSV-03P-25NBGN-R0 [†] 2/2KSV-03N-25NBGN-R0 ^{**}
Manual		2/2KSV-03P-25NBGN-MAN [†] 2/2KSV-03N-25NBGN-MAN ^{**}
		Type: NW6
Electromagnetic Example for 24 volts		2/2KSV-06P-25NBNN-ED024 [†] 2/2KSV-06N-25NBNN-ED024 ^{**}
Hydraulic		2/2KSV-06P-25NBGN-Z320 [†] 2/2KSV-06N-25NBGN-Z320 ^{**}
Pneumatic		2/2 KSV-06P-25NB GNN-Z064 [†] 2/2 KSV-06N-25NB GNN-Z064 ^{**}
Mechanical(roller)		2/2KSV-06P-25NBGN-R0 [†] 2/2KSV-06N-25NBGN-R0 ^{**}
Manual		2/2KSV-06P-25NBGN-MAN [†] 2/2KSV-06N-25NBGN-MAN ^{**}

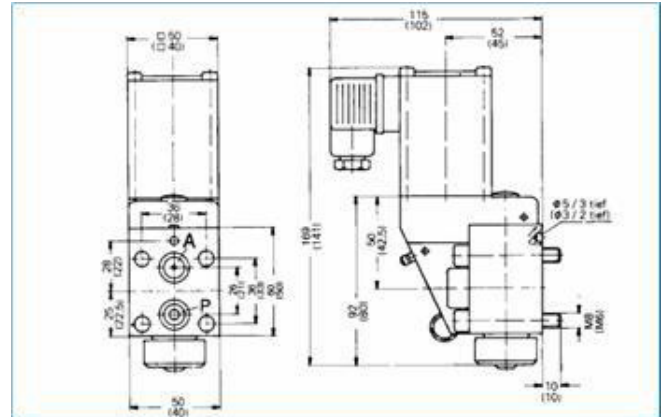

* Version "positive" = closed de-energized

** Version "negative" = open de-energized

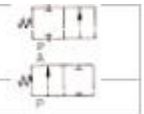

	NW3 infeed + working line	NW6 infeed + working line
connection bore	3	6
O-ring	9,25*1,78	12*2,5

VALVE VERSION "POSITIVE"

(Valve passage from „P“ to „A“ is closed when magnet is de-energized)

Fig. 1 (electromagnet de-energized):

The medium fed in via infeed „P“ presses the valve ball (4) into the valve seat (5), supported by the pressure spring (2). Thus the passage from infeed „P“ to working line „A“ is blocked.

Fig. 2 (electromagnet energized):

When the electromagnet (1) is switched on, the solenoid plunger (8) presses the valve ball (6) - via lever (9) and pushrod (10), and against the force of the pressure spring (2) - into the valve seat (7). Now drain „R“ is blocked. At the same time, using the spacer pin (3), the valve ball (4) is pressed out of the valve seat (5), so that the passage from infeed „P“ to working line „A“ is now clear.

electromagnet de-energized electromagnet energized

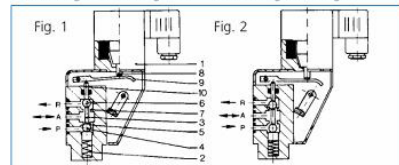

- P = infeed
- A = working line
- R = return
- 1 electromagnet
- 2 pressure spring
- 3 spacer pin
- 4 valve ball
- 5 valve seat
- 6 valve ball
- 7 valve seat
- 8 solenoid plunger
- 9 lever
- 10 + 11 pushrod

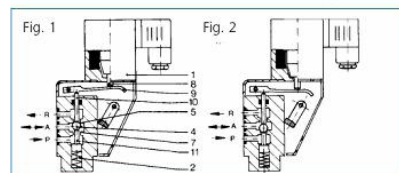

- P = infeed
- A = working line
- R = return
- 1 electromagnet
- 2 pressure spring
- 3 spacer pin
- 4 valve ball
- 5 valve seat
- 6 valve ball
- 7 valve seat
- 8 solenoid plunger
- 9 lever
- 10 + 11 pushrod

dimensional drawing DN 3 and DN 6
 DN 3 dimensions shown in brackets

P = infeed
 A = working line
 R = return

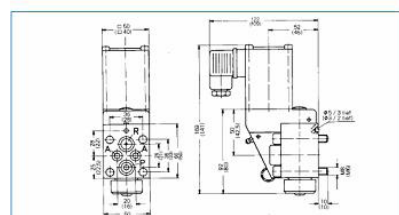

VALVE VERSION “NEGATIVE”

(Valve passage from „P“ to „A“ is open when the magnet is de-energized)

fig. 1 (electromagnet de-energized)

The pressure spring (2) lifts the valve ball (4) via pushrod (11) into valve seat (5). The medium flowing from infeed „P“ to the working line supports the pressure spring action. Thus the drain „R“ is blocked and the infeed „P“ is connected to the working line „A“.

fig. 2 (electromagnet energized)

When the electromagnet (1) is switched on, the solenoid plunger (8) presses the valve ball (4) via lever (9) and pushrod (10) and against the force of the pressure spring (2) and the pressure of the medium in the infeed „P“ - into the valve seat (7). Now the infeed „P“ is blocked and the working line „A“ is connected to drain „R“.

TYPE AND ORDER EXAMPLE

Operating modes	Sinnbild	Type: MW3
Electromagnetic Example for 24 volts		3/2KSV-03P-25NBNN-ED024 [†] 3/2KSV-03N-25NBNN-ED024 ^{†*}
Hydraulic		3/2KSV-03P-25NBGN-Z320 [†] 3/2KSV-03N-25NBGN-Z320 ^{†*}
Pneumatic		3/2 KSV-03P-25NBGN-Z064 [†] 3/2 KSV-03N-25NBGN-Z064 ^{†*}
Mechanical (roller)		3/2KSV-03P-25NBGN-R0 [†] 3/2KSV-03N-25NBGN-R0 ^{†*}
Manual		3/2KSV-03P-25NBGN-MAN [†] 3/2KSV-03N-25NBGN-MAN ^{†*}
		Type: MW6
Electromagnetic Example for 24 volts		3/2KSV-06P-25NBNN-ED024 [†] 3/2KSV-06N-25NBNN-ED024 ^{†*}
Hydraulic		3/2KSV-06P-25NBGN-Z320 [†] 3/2KSV-06N-25NBGN-Z320 ^{†*}
Pneumatic		3/2 KSV-06P-25NBGN-Z064 [†] 3/2 KSV-06N-25NBGN-Z064 ^{†*}
Mechanical (roller)		3/2KSV-06P-25NBGN-R0 [†] 3/2KSV-06N-25NBGN-R0 ^{†*}
Manual		3/2KSV-06P-25NBGN-MAN [†] 3/2KSV-06N-25NBGN-MAN ^{†*}

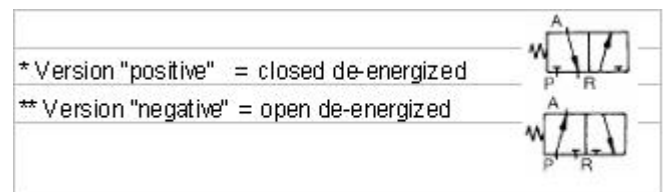

	NW3			NW6		
	P	R	A	P	R	A
connection bore	Ø3	Ø3	Ø3	Ø3	Ø3	Ø3
O- ring	9,25	9,25	6,07	12-	12-	8-2
	1,78	1,78	1,78	2,5	2,5	

VALVES

Valve body with console

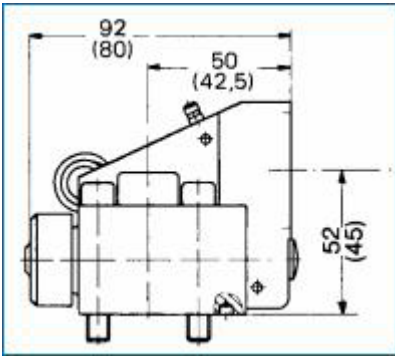

Mechanical operation

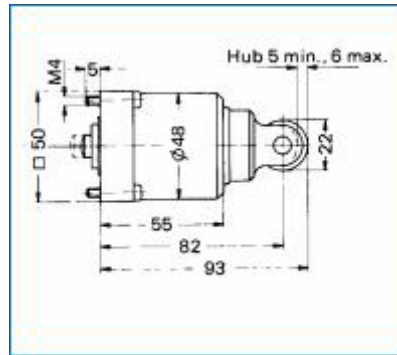

Hydraulic and pneumatic operation

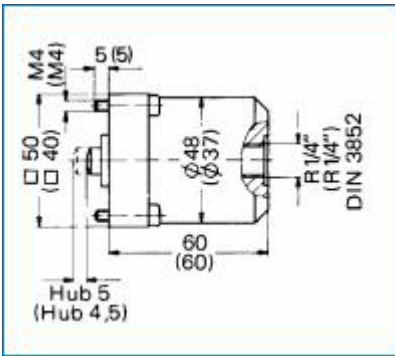

Manual operation

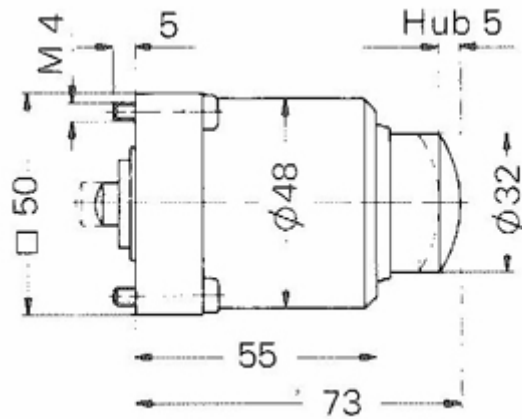

Pressure range:

Pneumatic 2,5-64 bar
 Hydraulic 2,5-64 bar
 22-320 bar

ELECTROMAGNETIC OPERATION NW3 AND NW6, FIREDAMP-PROOF AND EXPLOSION-PROOF

type dE4 (NW3) and dE3 (NW6), protection class acc.to VDE 0170/0171

NW3
 (Sch)d/(Ex)d2 G4 certificate No.T5681/BVS

NW6
 (Sch)d/(Ex)d2 G5 Besch.-Nr. T5538/BVS

NW3/Pg 16 DIN 22419 available for voltages from 12 - 240 V direct and alternating current.

power consumption
 up to approx. 20 Watt

connection cable
 112,5 - 14 mm (A15) NW6/Pg 21 DIN 22419 available for voltages from 24 - 500 V direct and alternating current.

power consumption
 up to approx. 32 Watt

connection cable
 15 - 19 mm (A19)

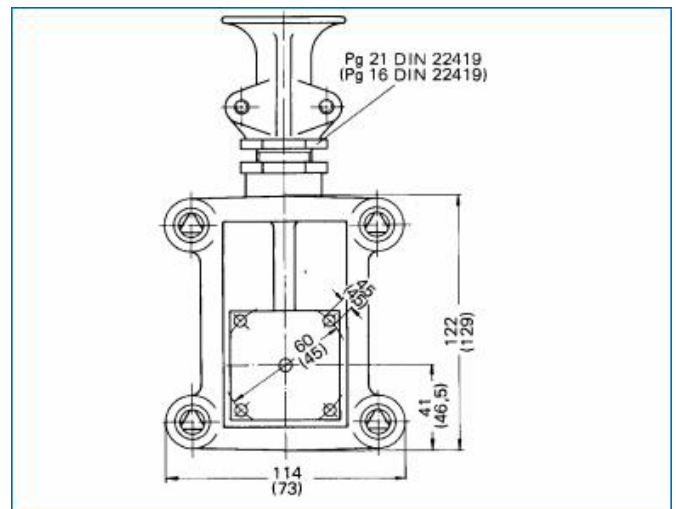

ACTUATOR NG3

actuator	NMG						
	electromagnet				hydraulic or pneumatic cylinder	roller actuation	
design type			dE4	dE4	Zyl. 31295	Zyl. 31887	mech.
protection class housing	IP 54 DIN 40050	IP 54 DIN 40050	(Sch) d(E) d2 G4 VDE 170/0171	(Sch) e(E) eVDE 0170/0171			
protection class connection compartment			(Sch) e(E) eVDE 0170/0171 IP 54 DIN 40050	(Sch) e(E) eVDE 0170/0171 IP 54 DIN 40050			
connection type	plug	plug	terminal	terminal	thread R 1/4"	thread R 1/4"	
control medium					oil in water emulsion, compressed air and neutral gases	oil in water emulsion, compressed air and neutral gases	
medium temperature					-30° C to +110° C	-30° C to +110° C	
ambient temperature	max.+35°C	max.+35°C	max.+40°C	max.+40°C	max.+80°C	max.+80°C	max.+80°C
pressure range					2,5-64 bar	25-320 bar	
mounting position	any	any	any	any	any	any	any
operating voltage*	24 V=	220 V ~	24 V=	220 V ~			
current intensity	0,54 A	0,06 A	0,54 A	0,06 A			
switch-on period	100% ED	100% ED	100% ED	100% ED			
pull-in power	13 W	13 W	13 W	13 W			
hold performance	13 W	13 W	13 W	13 W			
on period (100bar)							
off period							
lifting force	31 N	26 N	31 N	26 N			

CONNECTION PLATE NG3

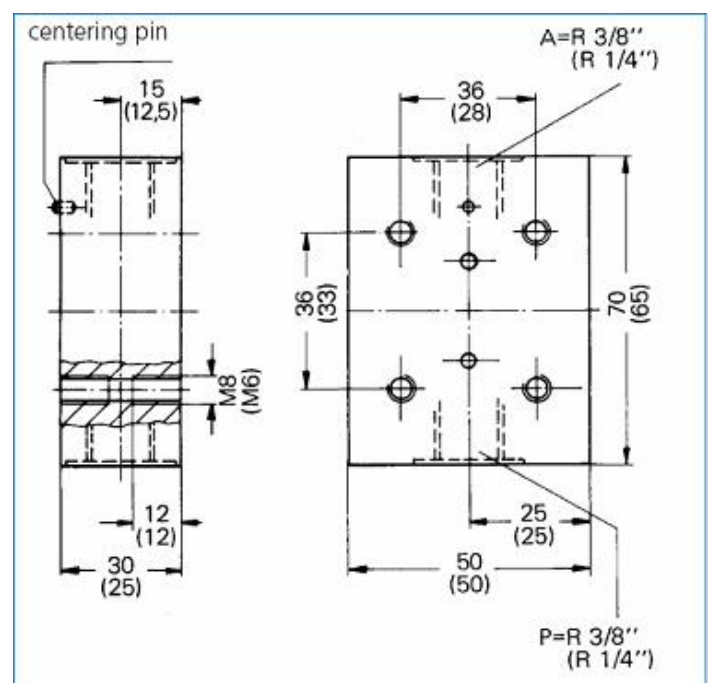
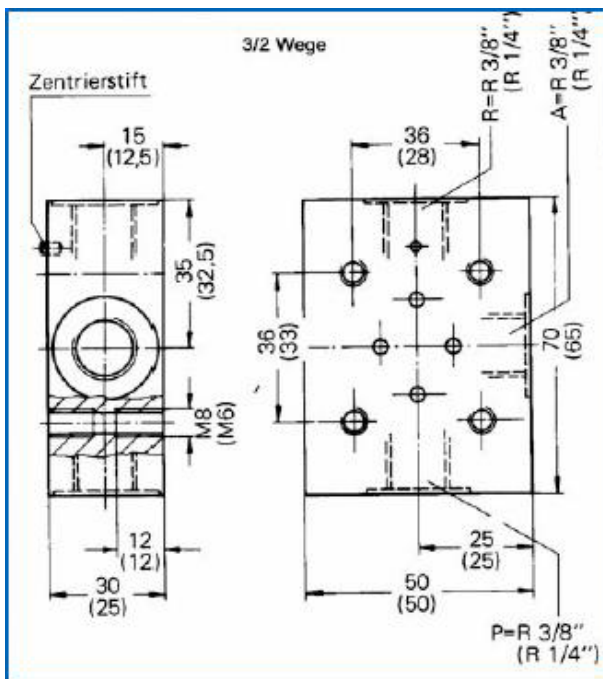

ACTUATOR NG6

actuator	NG6						
	Elektromagnet				Hydraulik- oder Pneumatikzylinder		Hydraulikzylinder
design type			dE3	dE3	Zyl. 31110	Zyl. 31136	mech. 31099
protection class housing	IP 54 DIN 40050	IP 54 DIN 40050	(Sch) d(E) d2 G4 VDE 170/0171	(Sch) d(E) d2 G4/ DE 170/0171			
protection class connection compartment			(Sch) e(E) eV DE 0170/0171	(Sch) e(E) eV DE 0170/0171			
connection type	Stecker	Stecker	Klemme	Klemme	Gewinde R1/4"	Gewinde R1/4"	
control medium					Öl in Wasser Emulsion ruckluft und neutrale gas e	Öl in Wasser Emulsion	
medium temperature					-30° C bis +110° C	-30° C bis +110° C	
ambient temperature	max.+35°C	max.+35°C	max.+40°C	max.+40°C	max.+80°C	max.+80°C	max.+80°C
pressure range					2,5-64 bar	25-320 bar	
mounting position	beliebig	beliebig	beliebig	beliebig	beliebig	beliebig	beliebig
operating voltage*	24 V=	220 V ~	24 V=	220 V ~			
current intensity	1,5 A	0,163 A	0,542 A	0,1318 A			
switch-on period	100% ED	100% ED	100% ED	100% ED			
pull-in power	36 W	36 W	13 W	13 W			
hold performance	36 W	36 W	13 W	13 W			
on period (100bar)	83 ms	73 ms	112 ms	124 ms			
off period	20 ms	113 ms	24 ms	80 ms			
lifting force	93 N	79 N	58 N	54 N			

CONNECTION PLATE NG6

